

## Using the Corning Cable Systems FBC-001 Optical Fiber Cleaver

### 1. General

1.1 The FBC-001 Fiber Cleaver (Figure 1) uses the score and snap method to quickly provide good quality fiber cleaves for fusion or mechanical splicing.

1.2 This procedure assumes that you have stripped and cleaned the fiber to be cleaved according to the appropriate fiber stripping procedure.

1.3 This issue includes updated corporate information.

### 2. Precautions



#### Safety Glasses

#### WARNING: Corning Cable

*Systems strongly recommends that you wear safety glasses to protect your eyes from accidental injury when handling chemicals, cutting fiber, or using compressed air to clean this cleaver. Pieces of glass fiber are very sharp and can damage the cornea of the eye easily.*



#### Glass Fiber Precautions

#### WARNING: Cleaved glass fibers

*are very sharp and can pierce the skin easily. Do not let cut pieces of fiber stick to your clothing or drop in the work area where they can cause injury later. Use tweezers to pick up cut or broken pieces of the glass fibers and place them on a loop of tape kept for that purpose alone. Good house-keeping is very important.*

### 3. Tools and Materials

3.1 In addition to the cleaver, you will need the following items:

- Vinyl tape
- Tweezers

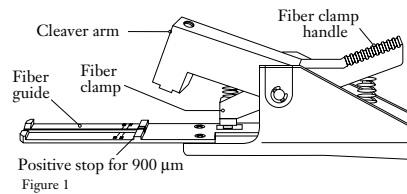

### 4. Procedure

4.1 Press down on the handle to open the cleaver's fiber clamp (Figure 2).

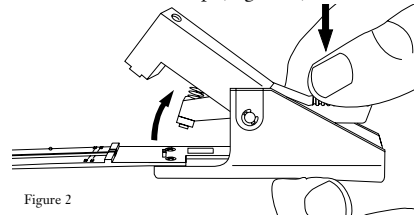

4.2 With your other hand, place the fiber(s) in the fiber guide so that the end of the fiber is under the fiber clamp and the end of the fiber coating lines up with the desired cleave length marking (Figure 3).

**DO NOT FLEX THE FIBER GUIDE AT THIS TIME.**

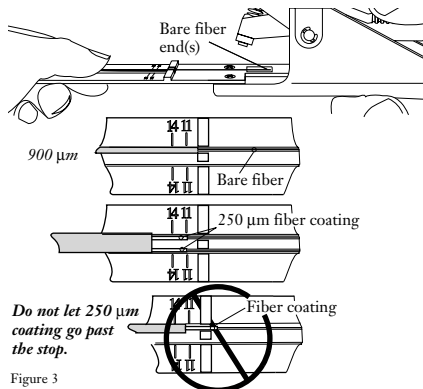

4.3 Gently release the handle to lower the clamp onto the bare fiber(s).

4.4 Press down the cleaver arm until it just touches the fiber and guide (Figure 4). This will apply enough pressure to properly score the fiber(s).

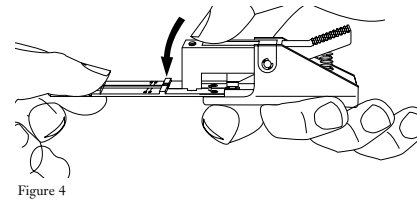

4.5 **CRITICAL STEP:** Gently release the cleaver arm.

4.6 Flex the fiber guide to snap the fiber(s) (Figure 5). The fiber is now ready for splicing.

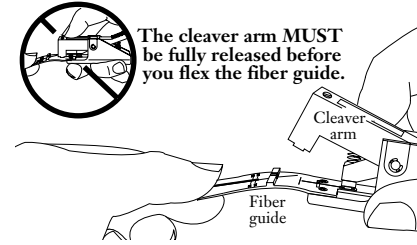

4.7 Press down on the cleaver's handle to once again lift the fiber clamp. Remove the end piece of fiber with tweezers and place the fiber on a loop of tape for proper disposal (Figure 6).

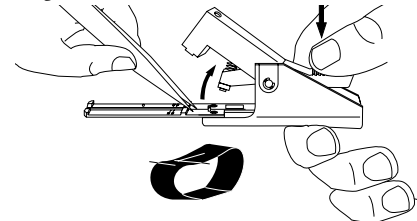

### 5. Maintenance

5.1 Thoroughly clean the cleaver after each use. Small fiber remnants left in the cleaver may cause damage to parts during later use.

5.2 Periodically clean the cleaver's blade, fiber guide, and fiber clamp with an alcohol-soaked wipe, followed by a cleaning with compressed air. **ALWAYS WEAR EYE PROTECTION WHEN CLEANING WITH COMPRESSED AIR.**

### Guide Replacement

5.3 To replace the fiber guide, you will need:

- new guide (p/n 100962-01)
- small Phillips head screwdriver.

5.4 To replace the fiber guide (Figure 7):

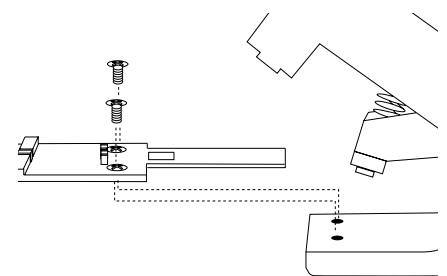

Figure 7

1. Use the screwdriver to remove the two screws located in front of the fiber clamp.
2. Press the handle to open the clamp, and remove the old guide.
3. Place the new guide under the clamp, being careful to line up the screw holes.
4. Release the fiber clamp. Reinsert the screws and tighten. **DO NOT OVERTIGHTEN THE SCREWS.**

Corning Cable Systems reserves the right to improve, enhance, and modify the features and specifications of Corning Cable Systems' products without prior notification.

All trademarks are the property of their respective holders.

Corning Cable Systems is ISO 9001 certified  
© 2001, 2002 Corning Cable Systems LLC. All rights reserved.

Printed in U.S.A.

Corning Cable Systems LLC  
PO Box 489  
Hickory, NC 28603-0489 USA  
For US and Canada 1-800-743-2673  
International 828-901-5000  
FAX: 828-901-5973  
<http://www.corning.com/cablesystems>